

INSTALLATION AND REMOVAL INSTRUCTIONS FOR B-LOC® KEYLESS BUSHING SERIES B115

B-LOC® Keyless Bushings provide a high capacity, zero-backlash shaft/hub or coupling connection by means of a mechanical interference fit. Please follow these **INSTALLATION AND REMOVAL INSTRUCTIONS** carefully to ensure proper performance of this **B-LOC®** unit.

ⓘ WARNING ⓘ

When installing or removing **B-LOC®** products, always adhere to the following safety standards:

1. Be sure that all power switches are locked out before installing or removing **B-LOC®** products.
2. Eye protection is required when installing or removing **B-LOC®** products - please wear safety glasses and protective clothing.

INSTALLATION

(Refer to Figures 1 and 2)

B-LOC® Keyless Bushings are supplied lightly oiled and ready for installation. When reinstalling a used unit, make sure that all slits are aligned and that front and rear clamp collars are not reversed (when assembled correctly there are no holes or threads behind taps in clamp collar Item 1, and no threads behind taps in center collar Item 3). The frictional torque capacity of these devices is based on a coefficient of friction of 0.12 for lightly oiled screw, taper, shaft and bore contact areas.

Therefore, it is important *not* to use Molybdenum Disulfide (e.g., Molykote, Never-Seize or similar lubricants) in any Keyless Bushing installation.

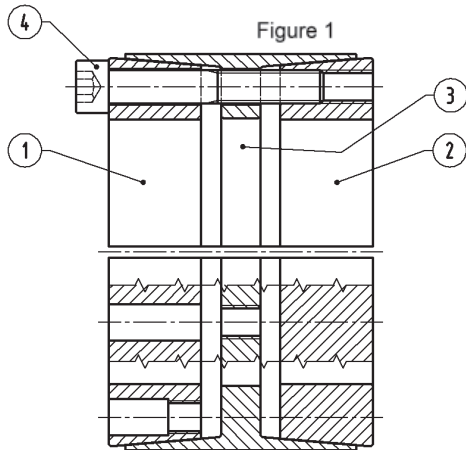

1. Make sure that locking screw, taper, shaft and bore contact areas are clean and lightly oiled and that all collar slits are aligned.
2. Loosen all locking screws by a minimum of four (4) turns and transfer at least two (2) screws to push-off threads in clamp collar Item 1 to disengage this part from center collar Item 3. Similarly, transfer at least two (2) screws to push-off threads in center collar Item 3 to disengage this part from clamp collar Item 2 (see Figure 2).
3. Completed assembly can now be placed on shaft and inserted into hub bore by pushing against face of collar Item 1 while ensuring that collar Item 2 is not engaged at tapers during this phase.
4. After placement of Keyless Bushing, relocate locking screws used for separation of collars.
5. Hand tighten connection and confirm that clamp collar Item 1 is parallel with face of part to be attached to shaft and/or with the front facing edge of center collar Item 3.
6. Use torque wrench and set it approximately 5% higher than specified tightening torque M_a . Tighten locking screws in either a clockwise or counterclockwise sequence (it is not necessary to tighten in a diametrically opposite pattern), using only 1/4 (i.e., 90°) turns for several passes until 1/4 turns can no longer be achieved.
7. Continue to apply overtorque for 1 to 2 more passes. This is required to compensate for a system-related relaxation of locking screws since tightening of a given screw will always relax adjacent screws. Without overtorquing, an infinite number of passes would be needed to reach specified tightening torque.
8. Reset torque wrench to specified torque (M_a) and check all locking screws. No screw should turn at this point, otherwise repeat Step 7 for 1 or 2 more passes. It is not necessary to re-check tightening torque after equipment has been in operation.

NOTE: In installations subjected to extreme corrosion, the slits in clamp collars Item 1 and Item 2, as well as in center collars, should be sealed with a suitable caulking compound or equivalent. Likewise, push-off threads should also be protected from corrosion.

INSTALLATION OF B-LOC® KEYLESS BUSHING OVER SHAFT KEYWAYS

The Keyless Bushing should be positioned so that slits in Keyless Bushing collars that contact the shaft are located approximately opposite the keyway. In addition, a locking screw should be centered directly over the keyway.

When tightening locking screws, it is important to follow the installation procedure outlined above, which specifies equal 1/4 turns of each locking screw. Failure to follow these instructions could result in excessive tightening of the screw over the keyway, possibly causing permanent deformation of the locking assembly collars. Even after 1/4 turns can no longer be achieved, it is important to continue to use equal turning angles for every screw until the specified tightening torque is reached.

REMOVAL

(Refer to Figure 2)

Prior to initiating the following removal procedure, check to ensure that no torque or thrust loads are acting on the Keyless Bushing, shaft or any mounted components.

IMPORTANT! Make sure ends of locking screws used for removal are ground flat and are slightly chamfered to prevent damage to screw and collar threads during push-off.

1. Check to ensure that axial movement of clamp collars - necessary for release of connection - is not restricted. Likewise, ensure that push-off threads are in good condition.

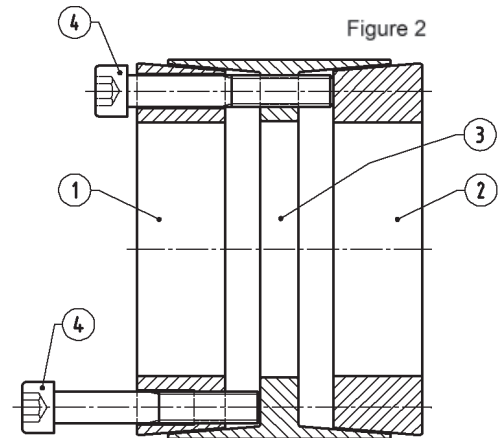

2. Remove all locking screws. Transfer required number of screws into all push-off threads of clamp collar Item 1 (see Figure 2).
3. Release collar Item 1 by progressively tightening all push-off screws. Typically, the push-off screws appear to be completely tight after just one pass of tightening without any noticeable separation of clamp collars. Although it seems that the screws cannot be tightened further, several more rounds of torquing in either a clockwise or counterclockwise sequence will increase the push-off force in the system and ultimately release part of the front collar. Afterwards, only the screws which are still tight should be tightened further until complete dismounting is achieved. Remove clamp collar Item 1.
4. Transfer locking screws used for dismounting of clamp collar Item 1 into all push-off threads in center collar Item 3 (see Figure 2). Release clamp collar Item 2 by repeating procedures outlined in Step 3.

LOCKING SCREW SIZES AND SPECIFIED TIGHTENING TORQUE M_a B115 KEYLESS BUSHING

Metric Series	Inch Series	Tightening Torque M_a (ft-lbs)	Screw Size	Hex Key Size (mm)
70 x 110 to 90 x 130	2-3/4 to 3-1/2	60	M 10	8
100 x 145 to 160 x 210	3-15/16 to 6	105	M 12	10
170 x 225 to 200 x 260	6-7/16 to 8	166	M 14	12
220 x 285 to 260 x 325		257	M 16	14
280 x 355 to 340 x 425		500	M 20	17
360 x 455 to 600 x 695		675	M 22	17